

UDC 621.317.73:644.1:517.9

V.V.Busher, PhD, V.V.Martynyuk, PhD, E.V.Naydenko, PhD,  
P.E.Khristo

### MODELING OF SUPERCAPACITORS WITH FRACTIONALLY INTEGRATED SECTION IN SIMULINK

**Abstract.** *There has been developed a model of fractionally-integrated section for SIMULINK with high accuracy and fast performance at the fixed calculation step. The proposed model is an improved version of the supercapacitor that takes into consideration the diffusive processes and parameters' variation on change of the current polarity.*

**Keywords:** *fractional integral, SIMULINK, supercapacitor.*

В.В. Бушер, В.В. Мартынюк, Найденко Е.В., кандидаты техн. наук,  
П.Е. Христо

### МОДЕЛИРОВАНИЕ СУПЕРКОНДЕНСАТОРОВ В SIMULINK С УЧЕТОМ ДРОБНО-ИНТЕГРИРУЮЩЕЙ СОСТАВЛЯЮЩЕЙ

**Аннотация.** *Разработана модель дробно-интегрирующего звена в SIMULINK, характеризующаяся высокой точностью и быстродействием при фиксированном шаге расчета. Предложена усовершенствованная модель суперконденсатора, учитывающая диффузионные процессы и изменение параметров суперконденсатора при изменении полярности тока.*

**Ключевые слова:** *дробный интеграл, SIMULINK, суперконденсатор.*

В.В. Бушер, В.В. Мартинюк, О.В. Найденко, кандидаты техн. наук,  
П.С. Христо

### МОДЕЛЮВАННЯ СУПЕРКОНДЕНСАТОРІВ У SIMULINK З УРАХУВАННЯМ ДРОБОВО-ІНТЕГРАЛЬНОЇ СКЛАДОВОЇ

**Анотація.** *Розроблено модель дробово-інтегральної ланки у SIMULINK, яка характеризується високою точністю та швидкодією при постійному кроці розрахунку. Запропонована удосконалена модель суперконденсатора, яка враховує дифузійні процеси та зміну параметрів суперконденсатора при зміні полярності струму.*

**Ключові слова:** *дробовий інтеграл, SIMULINK, суперконденсатор.*

#### Introduction

The supercapacitor based on the creation of the dual electrical layer (DEL), is described by fractional calculus [3,5,6] when in dynamic mode. Currently the study of the properties of the complex systems frequently performed utilizing SIMULINK. However, the methods of solving the fractional integral by MATLAB are not sufficiently developed [6], but for the modeling of the supercapacitor the approximate diagrams from the series-connected RC-chains or transfer functions with high integer order of differentiation and integration have been used. Such models make it possible to obtain reliable data in the limited frequency ranges.

The object of this task is a search for a rational method of calculus of the fractional integrals or derivatives in SIMULINK and development of these methods based on the model of supercapacitor, which can be included in the models of the electro mechanical devices, such as power drives of electric cars.

#### Theory and experimental data

Taking into consideration the properties of

© Busher V, Martynyuk V., Naydenko E., Khristo P., 2011

DEL as well as the experimental studies of the transient processes and Nyquist diagram of the supercapacitors, the model of the supercapacitor can be proposed. It will consist of the series-connected traditional elements – capacity  $C$  and internal resistance  $R$  and also the fractionally-integrated section, which simulates the processes of diffusion and adsorption (Fig. 1) [4]. The impedance of supercapacitor in this model is calculated from the transfer function between Laplace images of the current  $I(p)$  and the voltage  $U(p)$  in the following form:

$$H(p) = \frac{U(p)}{I(p)} = R + \frac{1}{Cp} + \frac{1}{Bp^\mu}, \quad (1)$$

where  $B$  – the diffusion coefficient,  $\mu$  – the fractional order of integration are in general within the limits  $0 < \mu < 1$ .

Experimental studies show that the parameters of the supercapacitor are changing in the charge and discharge modes. The reason for this is probably a thin layer of dipoles at the boundaries of the electrode- electrolyte triggered by the polar bonds between the surface of electrode and the oriented adsorbed atoms and molecules

of electrolyte and solvent [1]. This layer can change all parameters of supercapacitor due to a certain additional potential jump and sensitivity to the quality of the treatment of the surface of electrode and the composition of the environment. However, obtaining the measurements of this layer's parameters is practically impossible. But independent of the physical causes, it is possible to examine the groups of parameters during the charge of  $R_+, C_+, B_+, \mu_+$  and discharge of  $R_-, C_-, B_-, \mu_-$ .

In particular the identification of the parameters of the supercapacitor with the certified capacity of the 299 F of the charge and discharge processes led to the following data:

$$C_+ = 296 F, R_+ = 0.00154 \Omega, B_+ = 707, \mu_+ = 0.673$$

$$C_- = 294 F, R_- = 0.00143 \Omega, B_- = 873, \mu_- = 0.729.$$

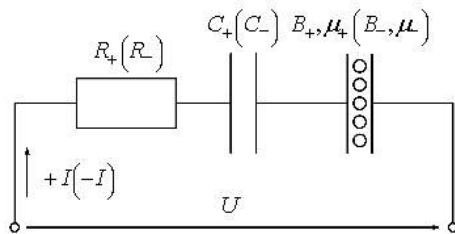

Fig. 1. The model of the supercapacitor

### Step time modeling

For the simulation of the transient processes in the supercapacitor it is necessary to create a model of the fractionally-integrated section. Let's use the modified form of Riemann-Liouville for step time fractional order calculus [2]:

$$I^\mu f_i = \frac{\Delta t^\mu}{\Gamma(\mu)} \sum_{j=1}^i f_{i-j} k_j^\mu, \quad (2)$$

$$k_j^\mu = \frac{j^{\mu+1} - (j-1)^{\mu+1}}{\mu(\mu+1)} - \sum_{n=1}^{j-1} k_n^\mu,$$

where  $\Delta t$  – the step of calculation.

With the fulfillment of calculation with the fixed step  $\Delta t$  during the given time interval  $t_p$  under zero initial conditions the fractional order integral of the function  $f$  in  $i$ -th moment of time is the result of the product of two one-dimensional vectors from  $n_p = \frac{t_p}{\Delta t}$  elements: the deliberate in the m-file vector  $\bar{k}$  and the filled at measure progression the calculation of  $\bar{f}$ . For the realization of this procedure let's utilize

the standard modules of SIMULINK to ensure an optimal and speedy solution of the task: *Memory* with the vector of initial conditions  $\bar{z}$ , *Selector* with the incoming input dimension  $n_p$  and index  $[1:n_p-1]$  as well as *Matrix concatenate* and *Dot product* with two vector entrances (Fig. 2).

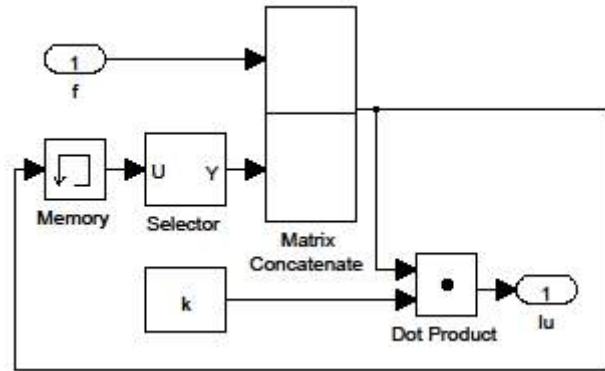

Fig. 2. The model of the fractional order integral

Based on this subsystem both the fractional integral and the fractional derivative of signal can be calculated considering the dependence of

$$D^{1-\mu} f_i = \frac{I^\mu f_i - I^\mu f_{i-1}}{\Delta t}.$$

### Results

Showing in Fig. 3 is the resulting model of the supercapacitor with the changing parameters in the charge/discharge modes and initial voltage of  $U_0$ .

Fig. 4 shows the graphs of the calculated transient processes in the regimes of charge, voltage regulation and discharge that are in agreement with the experimental processes. The integral parts of the voltages of the effective resistance  $U_R$  and diffusion element  $U_B$  are highlighted. For the supercapacitor with the above-indicated parameters the standard deviation of the calculated voltage compare to the experimental one comprised 0.0049V (0.38%) in the charge mode and 0.0035V (0.27%) in the discharge mode. It makes the degree of the authenticity of the described approach as highly believable.

Fig. 5 shows the reaction of supercapacitor to the harmonic signal, which is the basis for the Nyquist diagram of the supercapacitor with the

change in frequency. Due to nonlinear distortions the displacement of the phases  $\varphi_+$  measured between the maximum of current (or  $U_R$ ) and the voltage of the supercapacitor  $U_{SC}$ , will differ from  $\varphi_-$  between the minimums. Hence two Nyquist diagrams are possible. In Fig. 6 the set of such characteristics for the supercapacitor with the certified capacity of 120 F marked as  $Z_+$  and  $Z_-$ . It is evident that the experimental diagram  $Z_{EXP}$  and obtained on the criterion of the minimum standard deviation diagram  $Z_{SC}$  placed between  $Z_+$  and  $Z_-$ .

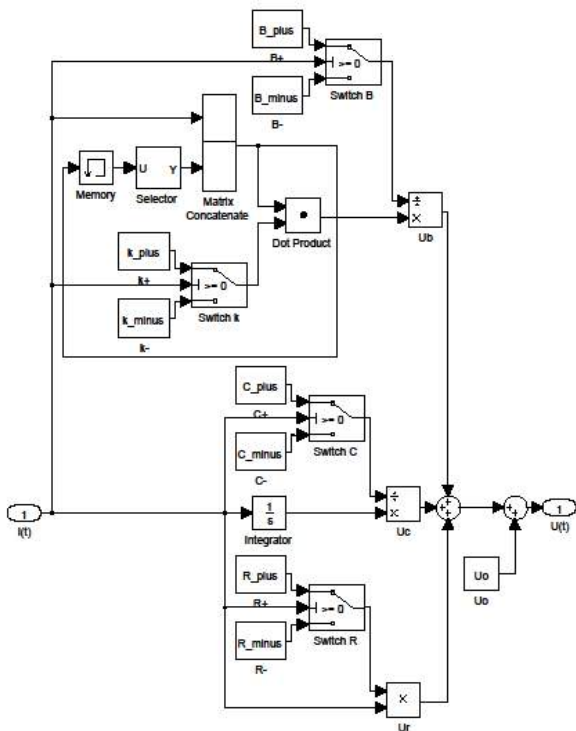

Fig. 3. The model of the supercapacitor in SIMULINK

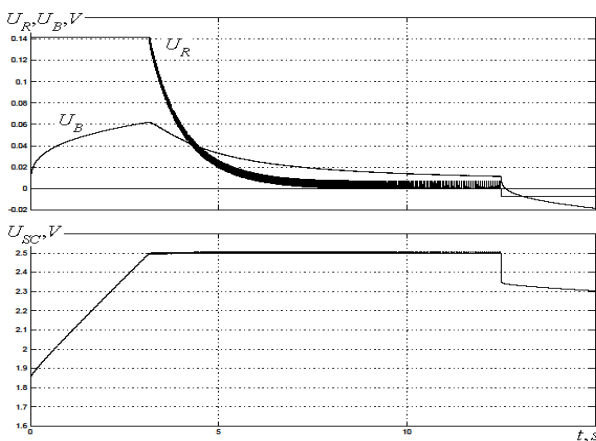

Fig. 4. Time-response characteristics in the charge, voltage regulation and discharge

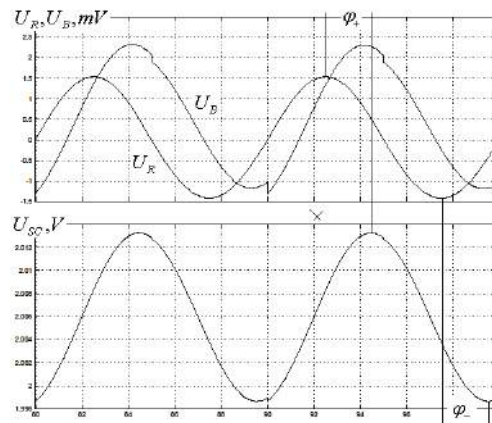

Fig. 5. Time-response characteristics of the supercapacitor to the incoming harmonic signal

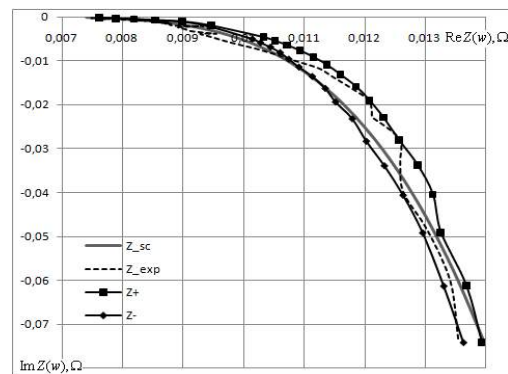

Fig. 6. Calculated and measured Nyquist diagrams

**Conclusions**

The model of the fractional order integral has been developed in SIMULINK, which makes it possible to investigate the properties of the systems with the fractional order  $0 < |\mu| < 1$  of integration and differentiation. This model uses various methods of the numerical solution of the differential equations with a fixed step providing high speed operation.

This model became a basis for the model of the supercapacitor characterized by a high degree of the authenticity in both the wide frequency range in the study of the reaction of supercapacitor to the harmonic signal, and the charging/discharging modes and voltage regulation. A change in the parameters of the supercapacitor due to the change of the polarity of the current has been realized in this model.

The proposed model can be easily integrated with the models of the electro-mechanical devices with the supercapacitors

including but not limited to the drives of the electric cars with the kinetic energy recovery systems KERS.

#### References

1. Arutyunyan V.M. The physical properties of boundary semiconductor-electrolyte // *The successes of physical sciences.* – Vol. 158.– No.2. – 1989. – P. 255–289 [in Russian].

2. Busher V.V. The identification of the elements of climatic systems by the differential equations of the fractional order // *Elektromashinobud. and elektroobladn.* – Kiev: Tekhnika. – 2010. – No. 75. – P.68-70 [in Russian].

3. Dzielinski A., Sierociuk D. Ultracapacitor Modelling and Control Using Discrete Fractional Order State-Space Model // *Acta Montanistica Slovaca.* – 2008. – Vol. 13. – № 1. – P.136-145 [in English].

4. Martynyuk V.V., Busher V.V. The model of super-capacitor with the fractional order integrator and identification methodology of its parameters // *Driving technology.* – Moscow: – 2011. – № 9–10 (109) [in Russian].

5. Quintana J. J. Identification of the Fractional Impedance of Ultracapacitors / J.J., Quintana, A.Ramos, I.Nuez // *Proceedings of the 2nd IFAC Workshop on Fractional Differentiation and its Applications.* – Porto, Portugal. – 2006. – P.127–136 [in English].

6. Vasil'yev V.V., Simak L.A. Fractional order calculus and approximating methods in the simulation of dynamic systems. – Kiev: NAS of the Ukraine, 2008. – 256 p. [in English].



Busher Victor V.  
Doctor of philosophy,  
Odessa national poly-  
technic university,  
t.+38(048)7610884



Martynyuk Valery V.  
Doctor of philosophy,  
Khmelnitsk national  
university,  
t. (0382)-222043



Naydenko E.V.  
Doctor of philosophy,  
Odessa national poly-  
technic university,  
t. +38(048)7797467



Khristo Pavel E.  
Odessa national poly-  
technic university,  
t. +38(0482)472811

Received 25.09.2011