

UDC 62-529

S. V. Zuev

CONTROL SYSTEM FOR DREGER'S SOIL WASHOUT LINE

Abstract. Main questions were considered for automating of soil washout hydraulic system for dredgers. It was shown, that modern systems for soil intake are not perfect and have to be under modernization. There was described a construction of developed impulse system for shock pressure waves supply. The main principle of the system's work based on creation of the water hummer inside the auxiliary pipeline, whose energy with the liquid through the number of jets, at the angle strikes the soil surface and destroying it. For the working process, based on the principle of water hummer, there was given a principal technological scheme. A list of main parameters was formulated, a diapason of which makes influence on the technology of automatic control of dredger production.

Keywords: dredger's production, water hummer, impulse washout system, pressure in the washout line, soil density, turbulent pulsations, hydraulic resistance, fluid dynamics forces, jet cross section, soil consistency in the slurry, structure scheme, automatic control line, primary measuring units, controller, protocol, self adapting wireless network, vibration measuring uni,

C. B. Зуев

СИСТЕМА РЕГУЛИРОВАНИЯ ЛИНИИ РАЗМЫВА ГРУНТА ЗЕМСНАРЯДА

Аннотация. Рассмотрены основные вопросы автоматизации системы гидродинамического размыва грунта при работе судов дноуглубительного флота. Показано, что современные системы грунтозабора являются несовершенными и требуют своей модернизации. Приведено описание конструкции разработанной импульсной системы подачи волн ударного давления. Основной принцип работы системы основан на создании во вспомогательном трубопроводе гидравлического удара, энергия которого с жидкостью через набор сопловых насадок под углом подается на поверхность почвы и разрушает ее. Для рабочего процесса, основанного на гидравлическом ударе, приведена принципиальная технологическая схема. Сформулирован перечень основных параметров, диапазон изменения которых определяет технологию автоматического регулирования производительности земснаряда.

Ключевые слова: производительность земснаряда, гидравлический удар, импульсная система гидроразмыва, давление в линии размыва, плотность грунта, турбулентные пульсации, гидроупругость, гидродинамические силы, консистенция грунта в пульпе, структурная схема, автоматизированная линия управления, первичные датчики, контроллер, протокол, самонастраивающаяся беспроводная сеть, вибродатчик

C. B. Зуєв

СИСТЕМА РЕГУЛЮВАННЯ ЛІНІЇ РОЗМИВАННЯ ГРУНТУ ЗЕМСНАРЯДУ

Анотація Розглянуті головні питання щодо автоматизації системи гідродинамічного розмивання ґрунту при роботі суден днопоглиблювального флоту. Показано, що сучасні системи грунтозабору недосконалі і потребують модернізації. Описано конструкцію розробленої імпульсної системи подачі хвиль ударного тиску. Базовий принцип роботи системи заснований на утворенні у допоміжному трубопроводі гідравлічного удару, енергія якого з рідиною через набір соплових насадок під кутом подається на поверхню ґрунту і руйнує його. Для робочого процесу, що базується на гідравлічному ударі, наведено принципову технологічну схему. Сформульовано перелік головних параметрів, діапазон зміни яких визначає технологію автоматичного регулювання продуктивності земснаряду.

Ключові слова: продуктивність земснаряду, гідравлічний удар, імпульсна система гідророзмивання, тиск у лінії розмивання, щільність ґрунту, турбулентні пульсації, гідропружність, гідродинамічні сили, консистенція ґрунту у пульпі, структурна схема, автоматизована лінія управління, первісні датчики, контролер, протокол, бездротова мережа, що сама налаштовується, вібродатчик

I. Introduction

An increase of productivity for the ships of dredging fleet is very important. For Ukraine, with a total coastline length equals 2835 km, the sea border 1355 km, and the length of waterway 71139 km the mining of clay and sandy soils is a very important direction, because these types of soils are more common during the dredging.

The density of natural layout of soil, its grain size distribution and the effect of the flow characteristics at the entrance to the vessel's soil intake device determine the total cost of the dredge operations. Total income from dredger's work may depend not only on the technical parameters of the equipment installed and the quality of the operator's work, but on the technology used for the soil extraction too.

© Zuev S.V., 2013

II. Materials of research

The main direction during productivity increase should be the modernization of individual technological unit components of the ship. One of such components is the unit of soil intake from the surface of the waterbed.

All modern ship's soil intake systems more often use two types of soil destroyers [8]. The first one is mechanical. They use the energy of mechanical destroy for soil pick up. They include cutters, drills, shovels, piles, etc. The main shortage of mechanical destroyers is the quick wearing of the cutting edges and strong performance dependence on the operating angle of the soil layer development [13].

The second type consists of hydraulic soil receivers. In comparison with mechanical systems during the extraction of clay and sandy soils the quality of their work is much higher. In hydraulic washout systems, for the transfer of destroying power to soil disruption a usual liquid is used. A set of pressurized jets provides a destroying of soil and creates near the suction intake hole a washout sphere with high soil consistency in slurry.

During the dredger's operation because of the destruction of the soil initial structure of natural abundance its density in the picking up operation changes. In such a case it is necessary to take into account the influence of the hydrodynamic processes that lead to its volume expansion especially near the cross section of inlet pipe. Because of the large-scale vorticity and high frequency turbulent fluctuations in the flow the flow-rate obtained may differ from the flow-rate in the suction region of the slurry receiver within the range from 8 to 50 % [11]. In this case, very important parameter is the entry speed on the level of suction hole. Its values for sand and clay should be differing from 1 to 1.5 m/s [3, 4]. The speed increase will always lead to the saturation of the slurry by soil.

During the research works there have been developed a new impulse system for soil washout [9, 10]. Main principle of its operation is based on the creation of hydraulic hummer inside the auxiliary pipeline. By means of very quick and strong pressure change the liquid enters the system of nozzle orifices and finally at an angle directed to the soil surface and destroys it. The main advantages of the developed system are:

– transformation of the fluid energy into the process of soil mechanical disruption without any additional mechanical;

– high dynamical characteristics of the dredge process;

– small sizes.

Impulse jets with high pressure are created by a system of electromagnetic valves. When the water hammer phases are chosen correctly it is possible to obtain a continuous surface destroying of the soil developed.

The simplest scheme of the worked out constructive solution is schematically shown in Fig. 1. By means of the work of automatically controlled valves 4 the water hummers are created in two lines 3 for water supply to the soil washout. Two pressure shock waves, which correspond to different phases of water hammer in Fig. 1 are denoted as "+" and "-". They pass the line 3 and finally enter the system of nozzle orifices. Due to the incompressibility of the fluid it is possible to provide the almost complete absence of the shock wave delay, even in those cases when the hydraulic system configuration change will be happening directly during operation.

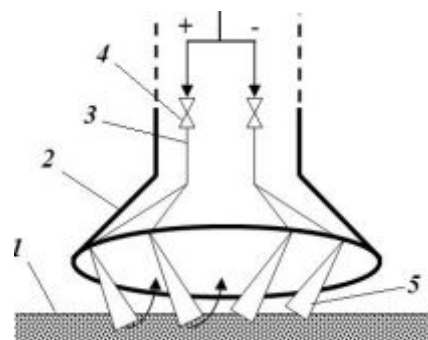

Fig. 1. The scheme of the hydraulic soil washout impulse system:
1 – soil; 2 – slurry intake unit; 3 – line for shock pressure waves discharge to the nozzle tip;
4 – control valves; 5 – shock pressure waves

From the point of view of hydraulic washout system reliability the very important value has a construction of electromagnetic valves, which are selected for pressure shock waves creation. During research works it have been stated that the most suitable construction had plunger ones. They are simple and could be characterized as a highly reliable.

The operational quality of the impulse hydro-washout system depends on its hydro elas-

ticity. The hydrodynamic forces, acting on the pipe wall, are depending on from the elastic deformation of walls during bending. When the shape is curved in space the internal fluid flow inside the pipe provides the pipe load both by the static and dynamic forces.

The nozzle tips are the main operational elements in the impulse system for the soil washout. In dependence on the nozzle geometry at constant dynamic system parameters during working jet outflow there can be achieved different values of reactive force. The effect of such force on the system of attachments and onto the hydro elasticity of the connected impulse washout line in conjunction with the weight loads is negative, but correctly chosen geometry of the nozzle will give an ability to increase the reaction force of the jet flow onto the ground.

When the hydro-washout system is working it is always necessary to check up the limitation value of the shock wave pressure [5]. For each temperature of the liquid there exists a critical pressure ratio $(P_2/P_1)_{cr}$ below of which there cannot be the increase of discharge velocity inside a jet nozzle. In other words, in determining the value of the shock pressure the smallest value of achieved shock pressure P_2 will always be known, and from an engineering point of view it is not necessary to exceed it.

The main performance parameter of the system is the mass flow rate of the working fluid during hydraulic hummer [5, 9]. For one nozzle, it is calculated as

$$Q_m = \varepsilon S_{out} \sqrt{2g\rho(P - P_{out})} \quad (1)$$

where S_{out} – cross section area of the nozzle exit; ε – flow rate factor; P – pressure of the flow at the nozzle inlet; P_{out} – the absolute pressure at the nozzle exit.

From (2) it is possible to find the required nozzle exit cross section area

$$S_{out} = \frac{Q_m}{\varepsilon \sqrt{2g\rho(P - P_{out})}} = 0,226 \frac{Q_m}{\varepsilon \sqrt{\rho(P - P_{out})}} \quad (2)$$

Providing of dredging operation with the use of hydrodynamic soil washout system requires constant monitoring of a number of important process parameters. These parameters are:

- pressure at the beginning and at the end of the working line 3 (Fig. 1) to determine the moment for opening/closing of the valve 4;

- the consistency of the slurry inside soil intake unit 2 to determine the phase of water hammer;

- the level of vibration of the working line 3 to check up the reliability of its attachment;

- flow rate and slurry density to determine the production volume of dredging.

III. Automatic Control System

To improve the efficiency, reliability and service life of the system, these parameters must be controlled automatically. The developed system of automatic control has been built on the base of industrial sensors and controllers that have been combined into a closed network. All sensors are manufactured by Emerson and use the original management, control and software systems. The governing of the system has been provided by PC. The main object for automating was the hydraulic network, consisted of the supply line for pulse pressure wave discharge to the nozzle tip and the soil suction pipeline.

The automatic control system performs the following:

- initial check of all line units;
- control of the slurry parameters;
- control of parameters in the pressure impulse line;
- electronic valves management for water hammer creation;
- real time display of the operating parameters during soil washout process;
- indication and alarm in disruption of operating conditions;
- alarm closure of auxiliary line.

To implement stated above functions, the automatic control system includes a pressure sensor, consistency measuring units, flow-rate, density of the slurry and vibration sensors.

All sensors and devices of the management system support the industry standard network Smart Wireless and protocol HART [7]. They give an ability to create reliable wireless systems for data collection and processing. In case of using wired sensors there could be used various devices for interfacing with a wireless network. The Emerson company produces for these purposes a special converter - Smart Wireless THUM Adapter [1].

WirelessHART is a reliable and easy to implement technology. It provides compatibility with existing HART-devices, instruments and

systems. Ships of dredgers fleet have quite dense infrastructure of large equipment, and working under changing conditions with the presence of multiple sources of radio and electromagnetic interference, which can significantly affect onto the reliability of data transmission. WirelessHART technology provides reliable data through transmission at the level of 99,9 % in all operating conditions [12].

As a control software for system governing providing there can be used software packages HART-Master, HART OPC-server, AMS Device Manager, Rosemount Radar Master, Radar Configuration Tools, Engineering Assistant, Visual Instrument, etc.

To connect a PC to a WirelessHART network must be used a wireless gateway. It provides self-tuning and constant check up of the system network sensors. Data transmission be-

tween the gateway and PC goes via Ethernet network at TCP/IP protocol. Wireless sensors form a self-adjusting sensors network (Fig. 2).

For electromagnetic valves governing on the lines of water hammer in the system of automatic control have been used the controller with the ability to connect to a PC via a wired or wireless network. Fig. 3 depicts a block diagram of the governing system for soil hydraulic washout.

The scheme based on the data transmission to the controller, governing the control of the electromagnetic valve, both on the PC and directly from the wireless sensor network gateway of the check up sensors. The proposed structural solution involves the implementation of the whole system with the use of wireless technologies too.

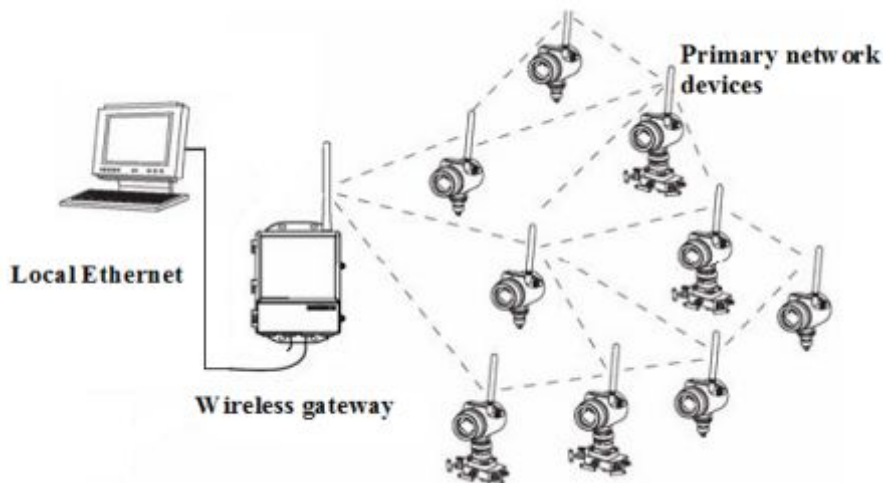

Fig. 2. Self-tuning wireless sensor network for management system

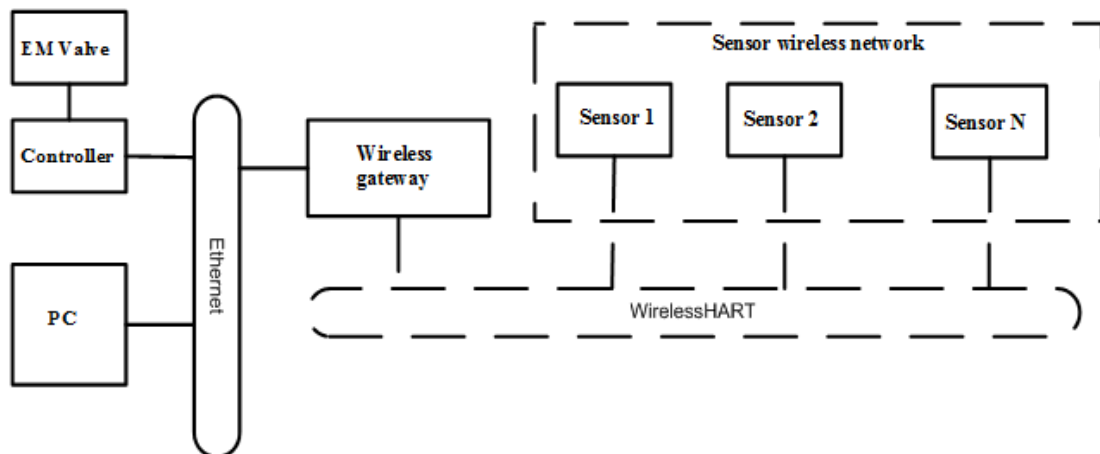

Fig. 3. Block diagram of the automatic control system for hydraulic soil washout

The control system works accordingly to the following algorithm (Fig. 4).

For automatic control system presetting in the vessel's working conditions in the test mode there must be determined the change ranges of the following parameters:

– allowable vibration level of impulse pressure hydraulic line;

– the range of working frequencies of the electromagnetic valves on the line of water hammer;

– the range of the pressure differences in the line of water hammer.

All the numerical parameters are entered in the database and in the future can be used to re-work, conducted under the same conditions.

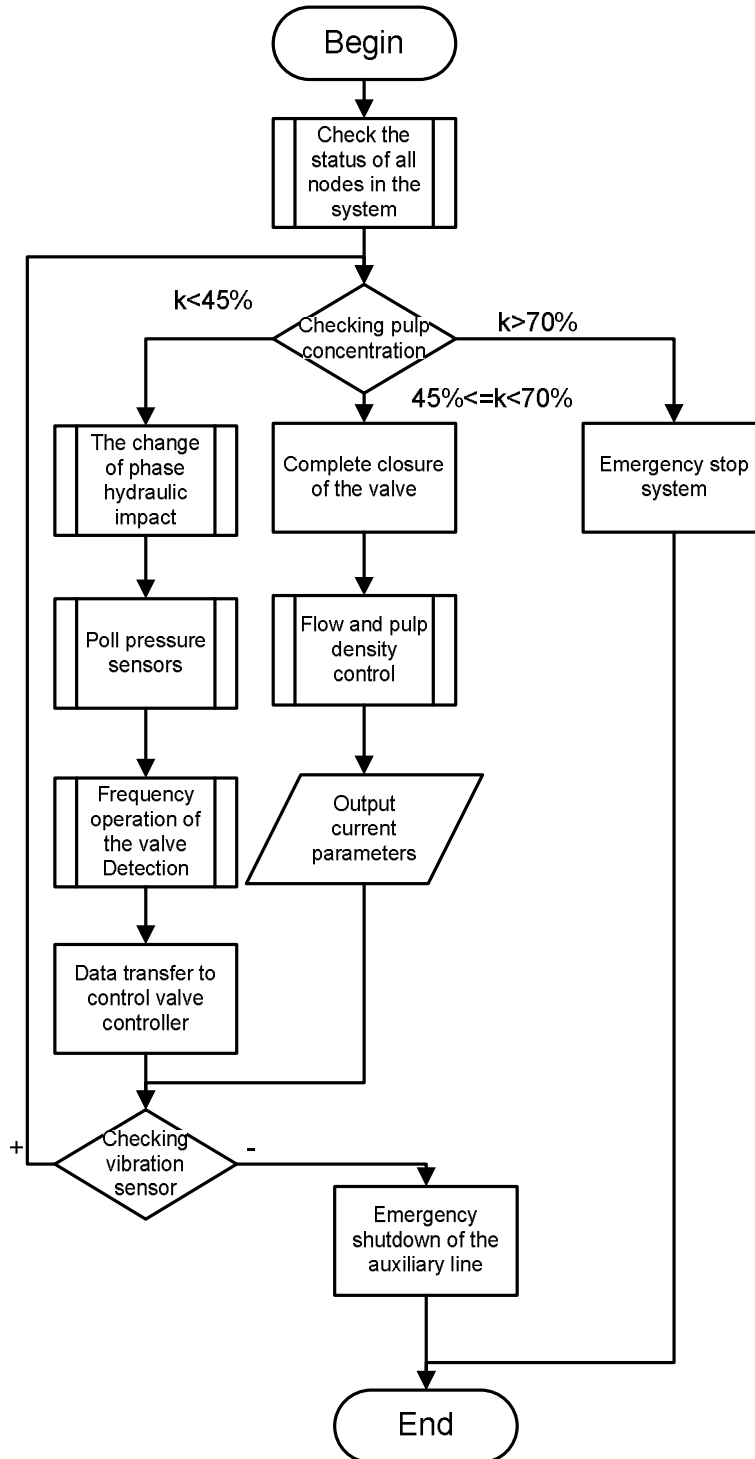

Fig. 4. Block diagram of the algorithm of the system

IV. Conclusions

1. The new hydraulic washout system can be considered as an alternative to all existing mechanical systems. It is characterized by simplicity, high reliability and significantly improves the productivity of the dredger.

2. The worked out algorithm of automatic control completely allows to exclude the influence of the operator onto the process of soil extraction and maintains the dredger's production at the highest level throughout the whole operating cycle.

3. The usage of wireless sensors and meters of the management system on the base of industry's networking standard Smart Wireless and HART protocol provides high noise immunity under any operating conditions.

References

1. Adapter Smart Wireless THUM, wireless level meter ROSEMOUNT. – Rosemount Tank Radar AB. Red. AC. May 2010, №. doc.: 109542RU. [Electronic resource] – Access mode.: http://www2.emersonprocess.com/siteadmindcenter/PM_Rosemount_Tank_Gauging_Documents/SmartWirelessTHUM_TG_109542RU_revAC.pdf – 10.05.2010.

2. Bessonov, E. A. Thechnology and mechanization of hydromechanical works / E.A Bessonov. – Moscow : Tsenter, 1999 [in Russian].

3. Boulden L. Moving solids like liquids *Vfch.* Dec., 1978. – P.87 – 92.96.

4. Elliot, D. E. Hydrotransport / D. E. Elliot, D. J. Gliddom // 1-st Int. Conf. Hydraul. transp. Solid Pipes,. 1980:120.

5. Instrumentation and Automation.- Ports and Dredging. – 1981. –No 110. – P.28–30.

6. Production Meter Helps Increase Dredge Production / John E. Wells // *World Dredging and Marine Construction*. – 1974. – V.10. – № 9. – P.14–16.

7. HART field communication protocol. – Application Guide HCF LIT 34, HART Communication Foundation, 1999. – 80 p.

8. Kolegaev, M. A. The construction features of the ship's system, with use of impulse pressure drops [M. A. Kolegaev, S. V. Zuev, A. V. Malahov, I. Z. Maslov, F. A. Bendeberya] // *Ship power plants: Science-technical maga-*

zine.– Odessa : ONMA. – 2012. – Iss.30. – P. 28 – 37 [in Russian].

9. Malahov, A. V. Hydro resistance of the ship impulse system for soil washout [Malahov A. V., Bendeberya F. A., Kolegaev M. A., Zuev S. V., Maslov I. Z. // *Annals of scientific papers SWorld. Matherials of international science-practical conference «Modern problems and their solution ways in science, transport, industry and education 2012».* – Odessa : Kuprienko, 2012. – Iss. 4. –Vol. 2. – P. 107 – 109 [in Russian].

10. Production Meter System-Aid for Suction Dredges. – *World Dredging & Marine Construction*, 1975. –Vol.11. – № 4. P. 30 – 32

11. Starikov A. S. Dredger's technological processes / A.S. Starikov – Moscow : Transport, 1989. – 220 p. [in Russian].

12. WirelessHART Training Resources. – HART Communication Foundation, 2013, [Electronic resource] – Access mode : http://www.hartcomm.org/protocol/training/training_resources_wihart.html – 12.03.2013.

13. Yaggy, T. An effectiveness of the hydro washout and claw usage on the injection core / T. Yaggy, I. Okayama // *In the book.: The technology of hydromechanical soil works.* – Moscow : Transport. – 1980. – P.43 – 52.

Received 15.04.2013



Zuev Sergey,
graduate student life safety
Odessa National Maritime Academy,
Didrikhsona st. 8, Odessa,
Ukraine, 65000.
tel. (048) 777-57-74